

QSR10GU

8x8 + 4x4 DBDC Wireless LAN Chipset Solution

PRODUCT BRIEF

Features

5GHz Modem

- Industry's highest performance 802.11ac/n/a wireless LAN chipset, combining high PHY/data link speed with reliable high data throughput over the maximum network diameter.
- Up to 8.6Gbps PHY/Data Link Speed in 160MHz mode
- Up to 8 streams in 8x8 MIMO configuration.
- BW support: 20MHz, 40MHz, 80MHz, 80+80MHz, 160MHz
- Modulation support: MCS 0-9, with support for proprietary 1024 QAM mode
- Support for unequal MCS
- Support for MU-MIMO and up to 4 users per group
- Support for LDPC, STBC
- Transmit Beamforming: support for 802.11ac and 802.11n
- HW Support for Singular Value Decomposition (SVD) for explicit Transmit Beamforming

2.4GHz Modem

- Support for 802.11n/g/b
- Up to 1.0Gbps PHY/Data Link Speed in 40MHz mode.
- Up to 4 streams in 4x4 MIMO configuration.
- BW support: 20MHz, 40MHz
- Modulation support: MCS 0-76, with support for proprietary 1024QAM mode
- Support for 2.4GHz Coexistence
- Support for explicit Transmit Beamforming

Applications

- Master Set-Top Boxes
- Multimedia Home Gateways
- Data Residential Gateways
- Access Points

Interfaces

Datapath	External Memory	Peripheral
• RGMII	• DDR3	• GPIO
• SGMII	• SPI Flash	• UARTs
• PCIe Gen 2.0	• Serial EEPROM	• SPI
• PCIe Gen 3.0		• I2C
• RXAUI		



Block Diagram

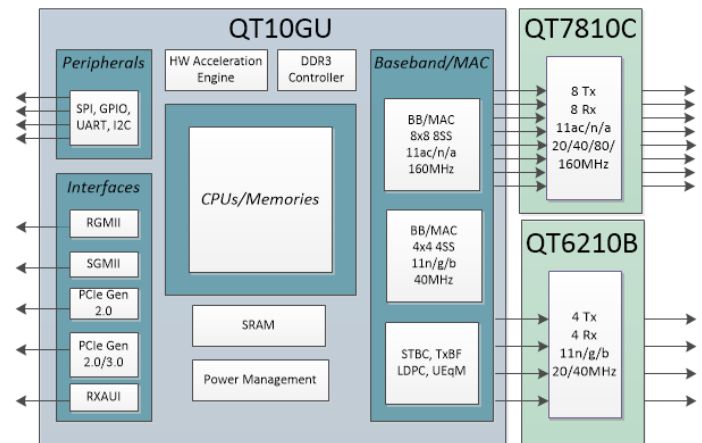

Software Support

Quantenna OS: Quantenna OS running on the integrated network processor enables equipment vendors to develop and port their own features and enhancements for value-add and additional BOM cost reduction.

Software Package: Complete software package for standard Access Point/Router and Vector Mesh Router in Linux with standard APIs to allow for easy porting.

Certifications: Worldwide Regulatory, Wi-Fi 802.11ac/n/a (WPA, WPA2 Personal/Enterprise, WMM, WMM-PS).

Physical Specifications

Baseband (QT10GU):

17.0mm x 17.0mm BGA, 546 balls

RFIC (QT7810C):

10.0mm x 10.0mm BGA, 225 balls

RFIC (QT6210B):

8.0mm x 8.0mm BGA, 121 balls



Quantenna Communications, Inc.

3450 W. Warren Avenue
Fremont, CA 94538 USA
www.quantenna.com